

# GX-1619B-SMARC

SynEdge AIoT ARM SoC Platform

User Manual

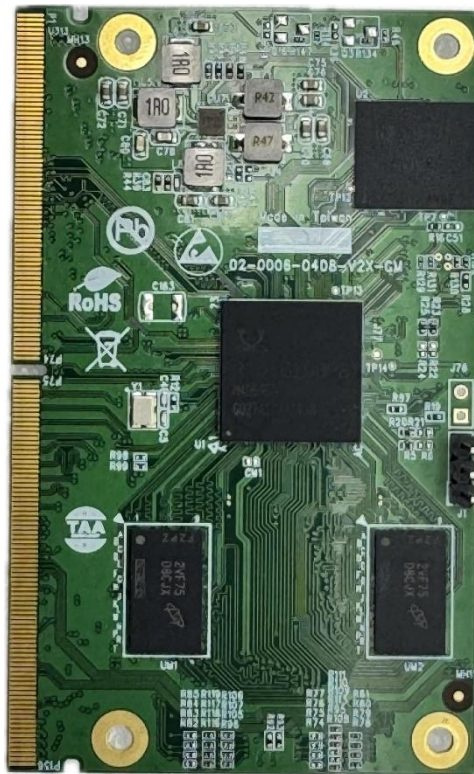

rev: 260417  
Made in Taiwan

## TABLE OF CONTENTS

INTRODUCTION.....	1
FEATURES.....	1
PACKAGE CONTENTS .....	2
SPECIFICATIONS .....	2
SYSTEM BLOCK DIAGRAM.....	3
PCBA DIMENSION .....	4
PIN DEFINITION.....	5
WARRANTY .....	8

## INTRODUCTION

The **GX-1619B-SMARC SynEdge AIoT ARM SoC Platform** is a compact microcomputer module based on the Realtek RTD1619B platform and designed according to the SMARC form factor specification. It is suitable for a wide range of embedded applications, including smart NVR systems, cloud terminals, industrial automation, Internet of Things (IoT) devices, and commercial display products.

Equipped with a quad-core ARM Cortex-A55 processor running at up to 1.7GHz, the GX-1619B-SMARC delivers high computing performance while maintaining low power consumption. Its built-in Mali-G57 GPU provides enhanced graphics and video processing capabilities, making the module ideal for AIoT equipment, in-vehicle control systems, entertainment and gaming devices, and other multimedia applications. With its modular design, developers can quickly complete product development and move into production simply by expanding the carrier board.

The GX-1619B-SMARC offers a wide variety of connectivity options, including MIPI DSI, I<sup>2</sup>C, SPI, UART, HDMI output, USB 3.0 (x1), and USB 2.0 (x2). These interfaces provide flexibility and compatibility for different system configurations.

Powered by the Realtek RTD1619B platform, the module includes a dedicated Video DSP that supports decoding of multiple video formats such as 4K AV1, H.265 (HEVC), H.264, VP9, VP8, MPEG-1/2/4, and VC-1. It also supports encoding up to Full HD resolution in H.265 (HEVC) and H.264 formats. In addition, the GX-1619B-SMARC supports JPEG image decoding and encoding, delivering strong multimedia performance for a wide variety of AIoT and embedded system applications.

## FEATURES

- High-Performance Computing
  - Equipped with a quad-core ARM Cortex-A55 processor, offering significantly improved CPU performance over previous A53/A55 implementations.
  - Features large private and shared CPU caches to optimize processing efficiency.
  - Integrated Mali-G57 GPU delivers up to 2× the graphics performance compared to the Mali-G31, enabling superior visual experiences.
- AI Edge Computing with Embedded NPU
  - Built-in Neural Processing Unit (NPU) designed for AI inference at the edge.
  - Seamlessly integrates with existing neural network frameworks on Linux to support real-time AI applications.
- Advanced Multimedia Support
  - Supports 4K decoding of AV1, HEVC (H.265), and VP9.2 formats for rich multimedia experiences.
  - Fully compatible with all major HDR standards for enhanced video quality and color accuracy.
  - Derived from the world's first SoC with native AV1 decoding capability
- High-Speed Connectivity
  - Integrated Gigabit Ethernet MAC + PHY for robust and efficient networking.
  - Includes a second Gigabit Ethernet interface, ideal for industrial and embedded applications.
  - Offers a variety of high-speed interfaces for flexible I/O expansion.
- Smart Display Capabilities
  - Supports dual independent display outputs via additional MIPI-DSI interface.
  - Designed for smart display applications requiring multi-screen or mirrored display setups

## PACKAGE CONTENTS

- 1x GX-1619B-SMARC PCBA
- 1x User Manual

## SPECIFICATIONS

Model Name		GX-1619B-SMARC
<b>Technical</b>		
SoC	RTD1619B	
Processor	OS	Ycoto / Ubuntu
	CPU	Quad core ARM Cortex A55 CPU 1.7GHz
	GPU	ARM Mali G57 ; Supports OpenGL ES1.1/2.0/3.2. OpenCL 2.0. Vulkan 1.1
	NPU	Integrated RKNN NPU AI accelerator, 1.6 Tops@INT8
	DDR4	4GB
	eMMC / SPI Flash	16GB (optional)/ SPI NOR Flash 2MB for bootloader (optional)
Ethernet	Ethernet	10/100/1000M
Interface	HDMI TX	*1
	USB 3.0	*1
	USB 2.0	*2
	MIPI-CSI	None
	SD Interface	*1
	IR Remote In	*1
	Ethernet	*1
	PCIe 2.0	*2
	MIPI-DSI	*1
	UART	*3
	I2C	*2
	I2S	*1
	SPI	*1
	GPIO	*15
Power	5V recommended	
Dimensions	82*50 mm	

# SYSTEM BLOCK DIAGRAM

## SoC Architecture

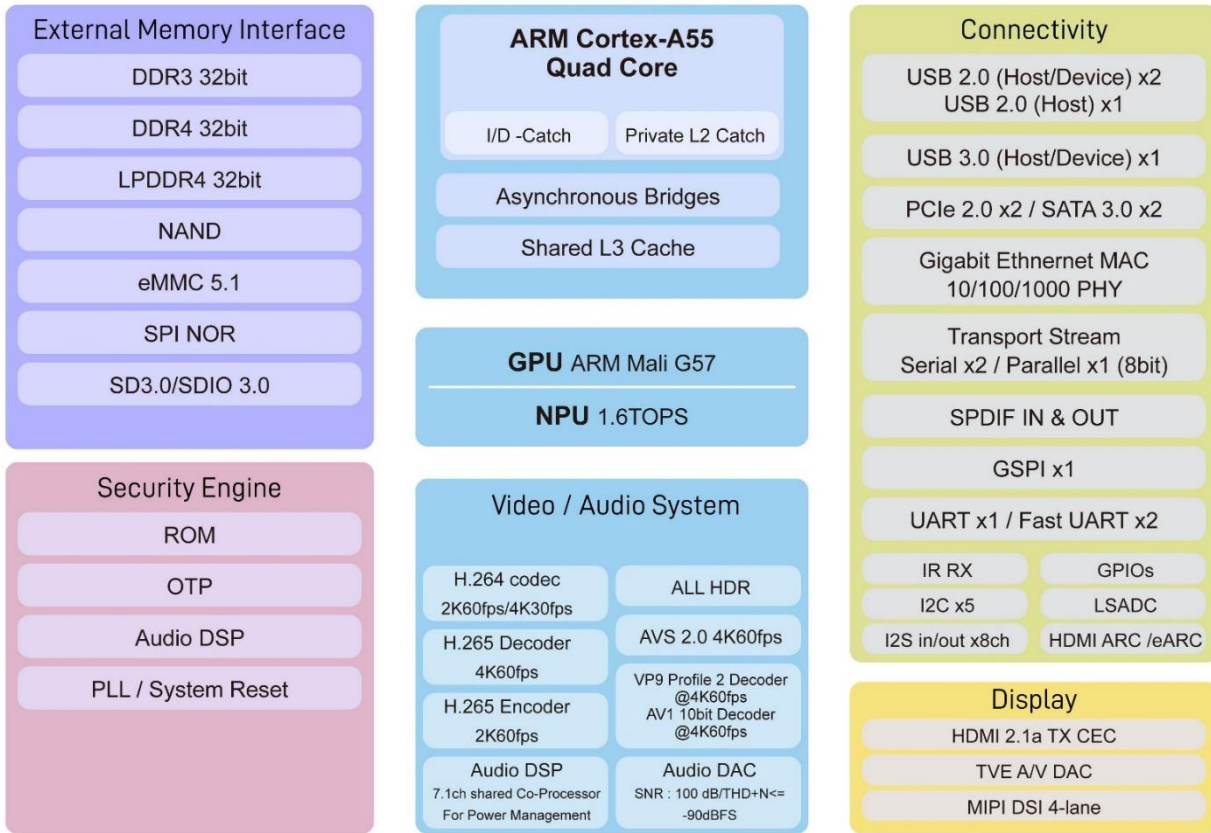

## System Block Diagram

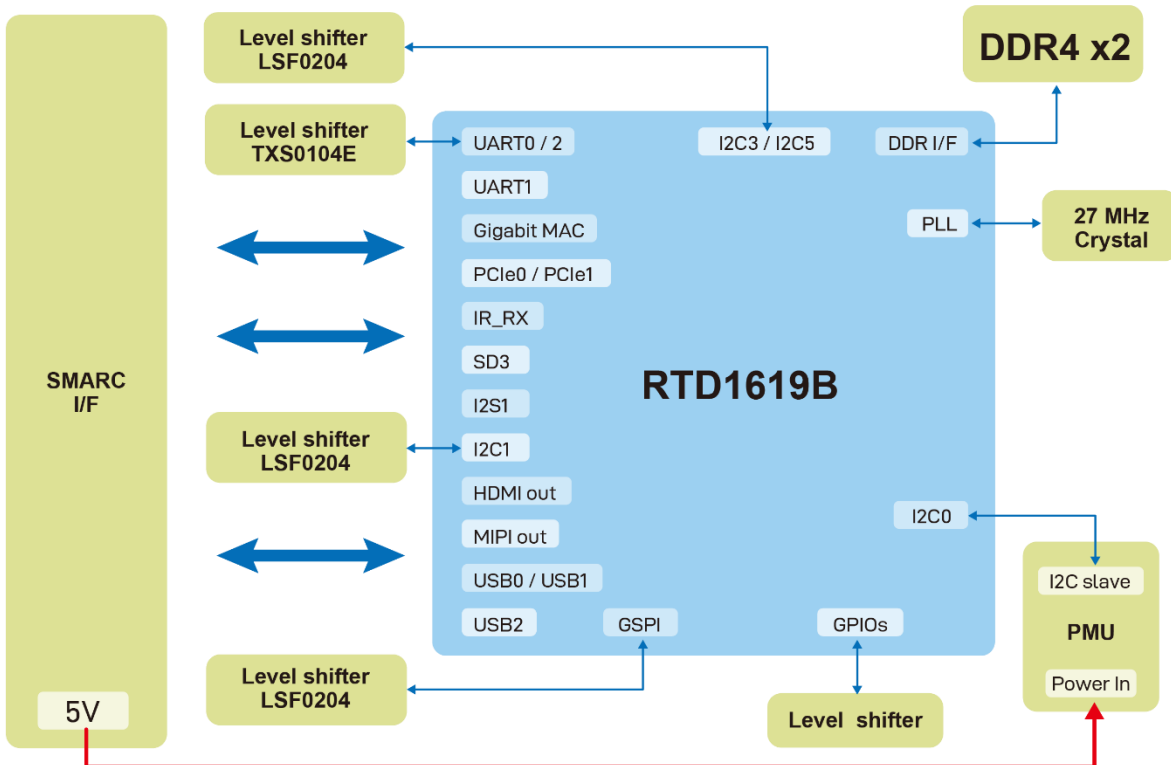

# PCBA DIMENSION

## PCB Dimension(82mm\*50mm)

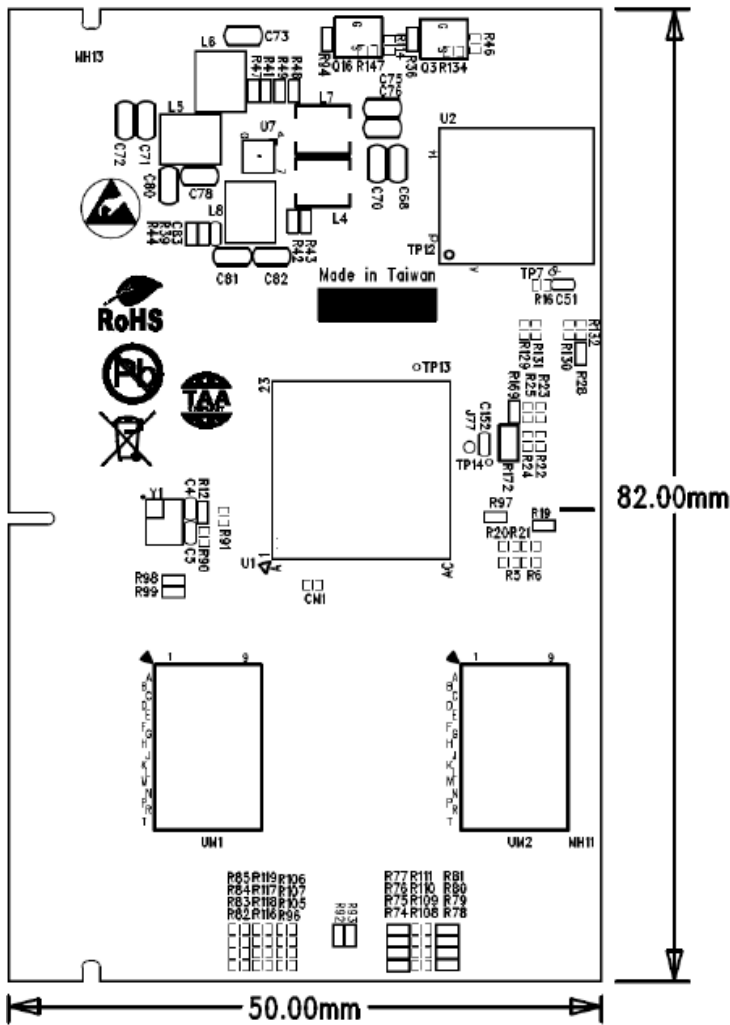

## PIN DEFINITION

### Primary Pin Definition

No.	Signal Name	No.	Signal Name	No.	Signal Name
P1	NC	P53	GND	P105	HDMI_DDC_SCL
P2	GND	P54	NC	P106	HDMI_DDC_SDA
P3	NC	P55	NC	P107	HDMITX_CEC
P4	NC	P56	NC	P108	GPIO65
P5	NC	P57	NC	P109	GPIO66
P6	NC	P58	NC	P110	GPIO67
P7	NC	P59	GND	P111	GPIO68
P8	NC	P60	USB2_DP0	P112	GPIO69
P9	GND	P61	USB2_DM0	P113	GPIO22
P10	NC	P62	NC	P114	GPIO47
P11	NC	P63	NC	P115	USB3_PWREN_GPIO49
P12	GND	P64	NC	P116	USB2_PWREN_GPIO48
P13	NC	P65	USB2_DP1	P117	GPIO70
P14	NC	P66	USB2_DM1	P118	HDMITX_PWR_EN_GPIO5
P15	GND	P67	NC	P119	GPIO71
P16	NC	P68	GND	P120	GND
P17	NC	P69	NC	P121	NC
P18	GND	P70	NC	P122	NC
P19	NC	P71	NC	P123	NC
P20	NC	P72	NC	P124	NC
P21	NC	P73	NC	P125	NC
P22	NC	P74	NC	P126	NC
P23	NC	P75	PCIE0_RST#	P127	RESET_IN#
P24	NC	P76	NC	P128	POWER_BTN#
P25	NC	P77	PCIE1_CLKREQ#	P129	NC
P26	NC	P78	PCIE0_CLKREQ#	P130	NC
P27	NC	P79	GND	P131	NC
P28	NC	P80	PCIE1_CKP	P132	NC
P29	NC	P81	PCIE1_CKM	P133	GND
P30	NC	P82	GND	P134	UART0_TX_DEBUG
P31	NC	P83	PCIE0_CKP	P135	UART0_RX_DEBUG
P32	GND	P84	PCIE0_CKM	P136	UART2_TX
P33	NC	P85	GND	P137	UART2_RX
P34	SD_CMD	P86	PCIE0_HSIP	P138	NC
P35	SD_CD	P87	PCIE0_HSIN	P139	NC
P36	SD_CLK	P88	GND	P140	NC
P37	SDCARD_PD	P89	PCIE0_HSOP	P141	NC
P38	GND	P90	PCIE0_HSON	P142	GND

P39	SD_D0	P91	GND	P143	UART1_TX
P40	SD_D1	P92	HDMITX_D2P	P144	UART1_RX
P41	SD_D2	P93	HDMITX_D2N	P145	NC
P42	SD_D3	P94	GND	P146	NC
P43	SPI_CS	P95	HDMITX_D1P	P147	VDD_IN_5V
P44	SPI_CLK	P96	HDMITX_D1N	P148	VDD_IN_5V
P45	SPI_MISO	P97	GND	P149	VDD_IN_5V
P46	SPI_MOSI	P98	HDMITX_D0P	P150	VDD_IN_5V
P47	GND	P99	HDMITX_D0N	P151	VDD_IN_5V
P48	NC	P100	GND	P152	VDD_IN_5V
P49	NC	P101	HDMITX_CKP	P153	VDD_IN_5V
P50	GND	P102	HDMITX_CKN	P154	VDD_IN_5V
P51	NC	P103	GND	P155	VDD_IN_5V
P52	NC	P104	HDMI_HPD	P156	VDD_IN_5V

### Secondary Pin Definition

No.	Signal Name	No.	Signal Name	No.	Signal Name
S1	NC	S53	NC	S105	NC
S2	NC	S54	NC	S106	NC
S3	GND	S55	NC	S107	NC
S4	IR_RX	S56	NC	S108	NC
S5	NC	S57	NC	S109	NC
S6	NC	S58	NC	S110	GND
S7	NC	S59	SPDIF_OUT	S111	NC
S8	NC	S60	SPDIF_IN	S112	NC
S9	NC	S61	GND	S113	NC
S10	GND	S62	USB3_HSOP	S114	NC
S11	NC	S63	USB3_HSON	S115	NC
S12	NC	S64	GND	S116	NC
S13	GND	S65	USB3_HSIP	S117	NC
S14	NC	S66	USB3_HSIN	S118	NC
S15	NC	S67	GND	S119	GND
S16	GND	S68	USB_DP2	S120	NC
S17	GBE1_MDI0+	S69	USB_DM2	S121	NC
S18	GBE1_MDI0-	S70	GND	S122	NC
S19	GBE1_LED1	S71	NC	S123	GPIO73
S20	GBE1_MDI1+	S72	NC	S124	GND
S21	GBE1_MDI1-	S73	GND	S125	MIPI_D0P
S22	GBE1_LED2	S74	NC	S126	MIPI_D0N
S23	GBE1_MDI2+	S75	NC	S127	NC
S24	GBE1_MDI2-	S76	PCIE1_RST#	S128	MIPI_D1P
S25	GND	S77	NC	S129	MIPI_D1N

S26	GBE1_MDI3+	S78	PCIE1_HSIP	S130	GND
S27	GBE1_MDI3-	S79	PCIE1_HSin	S131	MIPI_D2P
S28	GBE1_CTREF	S80	GND	S132	MIPI_D2P
S29	NC	S81	PCIE1_HSOP	S133	LCD0_VDD_EN / GPIO74
S30	NC	S82	PCIE1_HSON	S134	MIPI_CKp
S31	GBE1_LED0	S83	GND	S135	MIPI_CkN
S32	NC	S84	NC	S136	GND
S33	NC	S85	NC	S137	MIPI_D3P
S34	GND	S86	GND	S138	MIPI_D3N
S35	NC	S87	NC	S139	I2C5_SCL
S36	NC	S88	NC	S140	I2C5_SDA
S37	NC	S89	GND	S141	NC
S38	AI_Ck	S90	NC	S142	GPIO72
S39	AI_LRCK	S91	NC	S143	GND
S40	NC	S92	GND	S144	NC
S41	AI_SDI_0	S93	NC	S145	NC
S42	AI_BCK	S94	NC	S146	PCIE_WAKE#
S43	NC	S95	NC	S147	NC
S44	NC	S96	NC	S148	NC
S45	NC	S97	NC	S149	NC
S46	NC	S98	NC	S150	NC
S47	GND	S99	NC	S151	NC
S48	I2C3_SCL	S100	NC	S152	NC
S49	I2C3_SDA	S101	GND	S153	NC
S50	NC	S102	NC	S154	NC
S51	NC	S103	NC	S155	NC
S52	NC	S104	NC	S156	NC
				S157	NC
				S158	GND

## WARRANTY

The SELLER warrants the **GX-1619B-SMARC SynEdge AIoT ARM SoC Platform** free from defects in the material and workmanship for 1 year from the date of purchase from the SELLER or an authorized dealer. Should this product fail to be in good working order within 1 year warranty period, The SELLER, at its option, repair or replace the unit, provided that the unit has not been subjected to accident, disaster, abuse or any unauthorized modifications including static discharge and power surge. This warranty is offered by the SELLER for its BUYER with direct transaction only. This warranty is void if the warranty seal on the metal housing is broken.

Unit that fails under conditions other than those covered will be repaired at the current price of parts and labor in effect at the time of repair. Such repairs are warranted for 90 days from the day of reshipment to the BUYER. If the unit is delivered by mail, customers agree to insure the unit or assume the risk of loss or damage in transit. Under no circumstances will a unit be accepted without a return authorization number.

The warranty is in lieu of all other warranties expressed or implied, including without limitations, any other implied warranty or fitness or merchantability for any particular purpose, all of which are expressly disclaimed.

Proof of sale may be required in order to claim warranty. Customers outside Taiwan are responsible for shipping charges to and from the SELLER. Cables and power adapters are limited to a 30 day warranty and must be free from any markings, scratches, and neatly coiled.

The content of this manual has been carefully checked and is believed to be accurate. However, The SELLER assumes no responsibility for any inaccuracies that may be contained in this manual. The SELLER will NOT be liable for direct, indirect, incidental, special, or consequential damages resulting from any defect or omission in this manual, even if advised of the possibility of such damages. **Also, the technical information contained herein regarding the GX-1619B-SMARC Module features and specifications is subject to change without further notice.**